

This Page Is Inserted by IFW Operations  
and is not a part of the Official Record

## **BEST AVAILABLE IMAGES**

Defective images within this document are accurate representation of the original documents submitted by the applicant.

Defects in the images may include (but are not limited to):

- BLACK BORDERS
- TEXT CUT OFF AT TOP, BOTTOM OR SIDES
- FADED TEXT
- ILLEGIBLE TEXT
- SKEWED/SLANTED IMAGES
- COLORED PHOTOS
- BLACK OR VERY BLACK AND WHITE DARK PHOTOS
- GRAY SCALE DOCUMENTS

## **IMAGES ARE BEST AVAILABLE COPY**

**As rescanning documents *will not* correct images, please do not report the images to the Image Problem Mailbox.**

## INTERNATIONAL APPLICATION PUBLISHED UNDER THE PATENT COOPERATION TREATY (PCT)

(51) International Patent Classification <sup>4</sup> : <b>A61F 2/04</b>	<b>A1</b>	(11) International Publication Number: <b>WO 89/ 08433</b> (43) International Publication Date: 21 September 1989 (21.09.89)
-----------------------------------------------------------------------------	-----------	------------------------------------------------------------------------------------------------------------------------------------

(21) International Application Number: PCT/US89/00937  
 (22) International Filing Date: 8 March 1989 (08.03.89)  
 (31) Priority Application Number: 166,093  
 (32) Priority Date: 9 March 1988 (09.03.88)  
 (33) Priority Country: US

(71)(72) Applicant and Inventor: LAZARUS, Harrison, M.  
 [US/US]; 853 13th Avenue, Salt Lake City, UT 84103  
 (US).

(74) Agents: ROSSA, Thomas, J. et al.; Trask, Britt & Rossa,  
 P.O. Box 2550, Salt Lake City, UT 84110 (US).

(81) Designated States: AT (European patent), AU, BE (European patent), CH (European patent), DE (European patent), FR (European patent), GB (European patent), IT (European patent), JP, LU (European patent), NL (European patent),

SE (European patent).

Published  
 With international search report.

(54) Title: ARTIFICIAL GRAFT AND IMPLANTATION METHOD

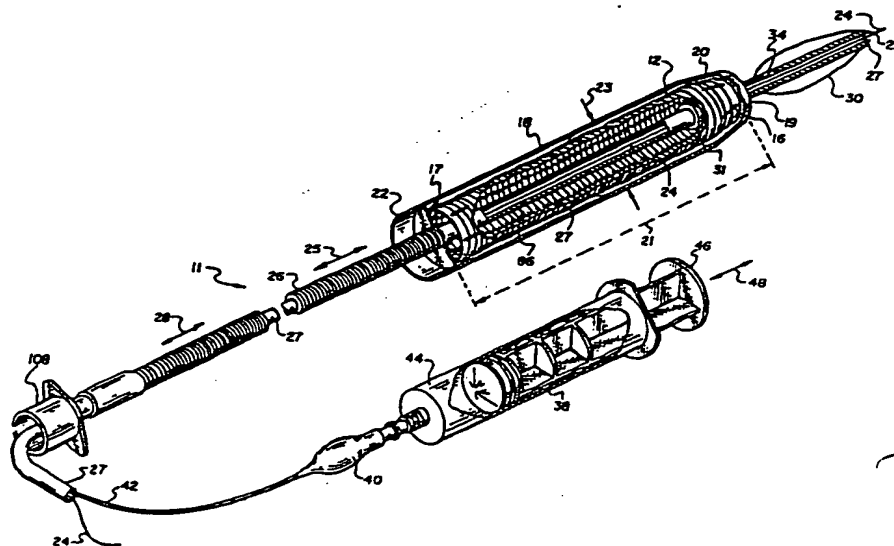

(57) Abstract

An intraluminal grafting system (11) includes a hollow graft (12) which has a proximal staple (16) and a distal staple (17). The system (11) includes a capsule (18) for transporting the graft (12) through the lumen and for positioning the graft (12) upstream in a lumen which may be a blood vessel or artery. A tube (26) is connected to the capsule (18) and extends to exterior the vessel for manipulation by the user. A catheter (27) is positioned within the tube (26) to extend from the cavity and through the graft (12) to exterior the body. The catheter (27) has an inflatable membrane (3) which is in communication via a channel with inflation and deflation means (38). With the inflatable membrane (30) deflated, the capsule (18) is positioned in the lumen and manipulated to desired location. The force exerted by the inflatable membrane (30) and the structure of the staples urges the staples in the vessel, retaining the graft in position.

**FOR THE PURPOSES OF INFORMATION ONLY**

Codes used to identify States party to the PCT on the front pages of pamphlets publishing international applications under the PCT.

AT	Austria	FR	France	ML	Mali
AU	Australia	GA	Gabon	MR	Mauritania
BB	Barbados	GB	United Kingdom	MW	Malawi
BE	Belgium	HU	Hungary	NL	Netherlands
BG	Bulgaria	IT	Italy	NO	Norway
BJ	Benin	JP	Japan	RO	Romania
BR	Brazil	KP	Democratic People's Republic of Korea	SD	Sudan
CF	Central African Republic	KR	Republic of Korea	SE	Sweden
CG	Congo	LI	Liechtenstein	SN	Senegal
CH	Switzerland	LK	Sri Lanka	SU	Soviet Union
CM	Cameroon	LU	Luxembourg	TD	Chad
DE	Germany, Federal Republic of	MC	Monaco	TG	Togo
DK	Denmark	MG	Madagascar	US	United States of America
FI	Finland				

## ARTIFICIAL GRAFT AND IMPLANTATION METHOD

Background of The Invention

5

Field: This invention relates to a medical prosthesis and, more particularly, to a graft prosthesis for placement within a corporeal lumen, such as the lumen of a blood vessel or artery.

10

State of the Art: Various fluid conducting body lumens, such as veins and arteries, may deteriorate or suffer trauma so that repair is necessary. For example, various types of aneurysms or other deteriorative diseases may affect the ability of the lumen to conduct fluids and in turn may be life-threatening. In some cases, the damaged lumen is repairable only with the use of prosthesis such as an artificial vessel or graft.

15

20

For repair of vital vessels such as the aorta, surgical techniques employed involve major surgery in which an artificial section of vessel is spliced into the diseased or obstructed lumen. That is, the damaged or diseased portion of the lumen may be surgically removed or bypassed and an artificial or donor graft inserted and stitched to the ends of the vessel which were created by the removal of the diseased portion. Kaj Johansen, Aneurysms, Scientific American, 247:110-125, July 1982. A variation of the typical suturing technique is described by Albert W. Krause, et al., Early Experience with Intraluminal Graft Prosthesis, American Journal of Surgery, 145:619-622, May 1993. The device illustrated in U.S. Patent 3,908,662 to Razgulov, et al. is an example of a device to be used in such a surgical procedure.

25

30

35

Other devices for the repair of lumens or vessels such as veins and arteries include a nitinol coil with a graft. The nitinol coil is reduced in dimension when cool. When placed in the body its temperature increases, and it returns to a preselected dimension to hold a graft within the lumen of the vessel. Such devices

are discussed in detail in Charles T. Dottner, et al., Transluminal Expandable Nitinol Coil Stent Grafting: Preliminary Report, Radiology 147:259, April 1983, and Andrew Cragg, et al., Nonsurgical Placement of Arterial Endoprostheses: A New Technique Using Nitinol Wire, Radiology 147:261-263, April 1983. The use of devices such as the previously discussed nitinol wire may not be desirable due to the danger of penetrating and damaging the vessel's wall during the emplacement process.

U.S. Patent 4,140,126 to Choudhury discloses a device for intraluminal repair of an aneurysm. This device is positioned in a vessel in a collapsed form and then hooked into the vessel with hooks that are mechanically extended by the user. This device is mechanically complex and in turn is susceptible to mechanical failure.

Other intraluminal devices are known, for uses other than the repair of a diseased lumen or vessel. U.S. Patent 3,874,388 to King, et al. discloses a system for closing off a septal defect or shunt in the intravascular system in the myocardial area. U.S. Patent 3,334,629 to Cohn discloses a device for restricting the flow of blood. U.S. Patent 4,056,854 to Boretus, et al. teaches construction and placement of an artificial aortic heart valve. U.S. Patent 3,834,394 to Hunter et al. teaches construction of an intraluminal device to occlude a blood vessel. U.S. Patent 3,540,431 to Mobin-Uddin teaches construction of an umbrella-like filter for intraluminal use. MEDI-TECH, Inc. of Watertown, Massachusetts sells a device known as the GREENFIELD Vena Cava® filter for intraluminal placement. U.S. Patent No. 3,938,528 discloses a device that is implanted into the vas-deferens or similar lumen for the splicing of the lumen parts.

None of the devices noted above disclose a reliable and quick means or method to repair a vessel intraluminally.

Summary of the Invention

5 An artificial intraluminal prosthesis for  
placement in a fluid conducting corporeal lumen has a  
hollow graft of preselected cross-section and length. The  
proximal end of the graft is placed upstream within the  
lumen. The graft is deformable to conform substantially  
to the interior surface of the lumen. Staples are  
attached to the proximal end and preferably to the distal  
10 end of the graft for stapling the graft to the wall of the  
lumen.

Each staple has wall engaging members. The wall  
engaging members of the proximal staple are generally  
angulated in a downstream direction and have tips for  
engaging the vessel wall. The wall engaging members of  
15 the distal staple are angulated in a direction generally  
perpendicular to the longitudinal or central axis of the  
graft, and also have tips for engaging the wall.

Generally, the staples are formed into a V-  
20 shaped lattice or framework. In an alternative embodi-  
ment, the staples' framework is U-shaped or sinusoidal.  
The frame of the staples allows for radial deformation  
resulting in a spring-like effect when a compressed staple  
is allowed to expand within a vessel and to sustain itself  
25 in that expanded condition.

Preferably, the graft is made of a material  
suitable for permanent placement in the body such as nylon  
or dacron. Prior to emplacement, the graft is formed to  
be substantially cylindrical in shape and formed to have a  
30 plurality of substantially evenly placed circumferential  
bifolds along the length thereof. An optional radio-  
opaque seam on the exterior of the graft may run along the  
longitudinal axis of the graft in order for the user to  
observe graft placement through fluoroscopy or by x-ray.

35 The system for intraluminally engrafting the  
hollow graft has placement means for emplacing the graft  
into the lumen and positioning it at a preselected

position. The placement means includes a capsule shaped and sized for positioning within the lumen. A hollow tube extends from the capsule to exterior the vessel for manipulation by the user. The graft is retained within the capsule for positioning the graft in the lumen. The placement means includes operation means for removing the graft from the capsule and for subsequently urging the staples into the wall of the lumen.

Preferably, the operation means includes a catheter slidably positioned within the hollow tube to extend from the capsule to exterior the lumen. The catheter desirably has an inflatable membrane operable by means for inflating and deflating the membrane. Pusher means is attached to the catheter and sized for passing through the capsule and for urging the hollow graft with attached staples out of the capsule through an upstream or front end aperture.

After the proximal portion of the graft is removed from the capsule, the inflatable membrane is desirably moved to within the circumference of the proximal staple and inflated to urge wall engaging members of the proximal staple into the wall.

The balloon is then deflated, and the replacement means manipulated to remove the remainder of the graft from the capsule, thus exposing the distal staple. Preferably, the distal staple is placed and affixed in a manner similar to the proximal staple.

The placement means is then removed from the lumen.

#### Brief Description of the Drawings

In the drawings, which illustrate the best mode presently contemplated for carrying out the invention,

FIG. 1 is a partially cut-away perspective view of an intraluminal graft system of the instant invention;

FIG. 2 is a perspective view of a slightly bent

graft device of the instant invention;

FIG. 3 is an enlarged view of a proximal staple of the instant invention;

FIG. 4 is an enlarged view of a distal staple of the instant invention;

FIG. 5 is an enlarged side view of a capsule of the instant invention;

FIGS. 6, 6A and 7 are cross-sectional views of the intraluminal graft device and placement means of the instant invention showing an intraluminal graft being emplaced into a lumen;

FIG. 8 is a perspective exploded view of an alternate embodiment of the capsule;

FIG. 8A is a partial perspective of an alternate capsule;

FIG. 9 is an enlarged view of an alternate embodiment of a proximal staple of the instant invention;

FIG. 10 is an enlarged view of an alternate embodiment of a distal staple of the instant invention;

and

FIG. 11 is an enlarged partial view of an alternate embodiment of a staple of the instant invention.

#### Description of the Illustrated Embodiment

FIG. 1 illustrates a system 11 for intraluminally placing a prosthesis in a fluid conducting corporeal lumen. The system 11 includes a hollow graft 12 of preselected cross-section and length. The graft 12, as more fully shown in FIG. 2, has a proximal end 14 for placement upstream within a lumen such as a blood vessel. A proximal staple 16 is positioned proximate the proximal end 14 of the graft 12 and is here shown with portions extending through the graft 12 for stapling the graft 12 through the interior wall 13 of the graft 12 into the wall of the lumen. A distal staple 17 is positioned proximate the distal end 18 of the graft 12 and is here shown with



portions extending through the graft 12 for stapling the graft 12 to the interior wall 13 of the graft 12 into the wall of the lumen.

5 The system 11 (FIG. 1) includes placement means for inserting the graft 12 into the lumen and for positioning the graft 12 at a preselected position within the lumen. The placement means includes a capsule 18 which has a front 20 and a back 22. A tube 26 is affixed to the back 22 of the capsule 18 and sized in length 25 to extend exterior the body for manipulation by the user. 10 That is, the tube 26 can be manipulated to move the capsule 18. The placement means also includes operation means, as more fully discussed hereinafter and a wire guide 24.

15 The capsule 18 is sized for positioning in the lumen. As can be seen in FIGS. 1, 6 and 8, the capsule is hollow and is also sized in length 21 and cross section 23 to contain the graft 12 for transport through the lumen.

20 The operation means preferably includes a hollow catheter 27 slidably positionable over the wire guide 24. The catheter 27 has an inflatable membrane ("balloon") 30 positioned proximate the front end 29 of the catheter 27. Means to operate the membrane 30 between inflated and deflated conditions include a channel 34 formed in the wall of catheter 27 to be in fluid communication between 25 the interior of the inflatable membrane 30 and a syringe 38. The channel 34 extends along the length 28 of the catheter 27 to the syringe 38 or other means to insert and remove fluid to inflate and deflate the membrane 30.

30 A pusher means here shown as a cylindrically shaped button 31 is affixed to and surrounds the catheter 27. It is placed on the catheter 27 behind or downstream of the membrane 30 as best seen in FIGS. 1 and 6. The button 31 is sized to engage the graft 12 with staples 35 within the capsule 18 for urging the graft 12 with staples out of the capsule 18 as more fully discussed hereinafter.

As seen in FIG. 1, syringe mechanism 38 is connected through a connector 40 via an extension tube 42 to the channel 34. Those skilled in the art will recognize that the catheter 27 with the channel 34 and inflatable membrane 30 are very similar in both structure and function to a balloon dilation catheter. It should also be recognized that the syringe is preferably a conventional syringe having a sleeve 44 within which a hand actuated piston 46 is sealably and slidably movable in an inwardly and outwardly direction 48 to insert a fluid via the tube 42 and channel 34 to the membrane 30 to respectively inflate and deflate the membrane 30. The fluid inserted to inflate may be an air or saline solution or such other fluid as desired by the user. Of course the fluid may be extracted to deflate the membrane 30 by operating the piston 46 in an outward direction 48.

The artificial graft 12, shown in FIG. 2, is preferably made of a deformable material having a high tissue ingrowth rate. Various dacron, nylon and teflon materials as well as various polymer materials are regarded as suitable. At present the desired material has been found to be Plasma TFE<sup>®</sup> made by Atrium Medical Corp. of Clinton Drive, Hollis, New Hampshire (03049).

The graft 12 is preferably formed to have a plurality of substantially evenly spaced circumferential bifolds 50 (similar to the bifolds of a bifold door) along its length 52. The bifolds 50 facilitate both axial 54 and radial 56 deformation of the graft 12. Therefore, when emplaced, the graft 12 may readily conform to the interior shape of the lumen. The length 52 of the graft 12 is selected by the user. Typically, the length 52 of the graft 12 will be selected to be longer than the portion of the lumen to be repaired. The radial 56 or cross-sectional size of the graft 12 is also selected by the user typically to conform substantially to, or be slightly larger than, the interior cross-section of the

involved lumen. Since the graft 12 is made of a deformable material with bifolds, it can readily be collapsed or squeezed into the capsule 18.

As shown in FIG. 2, two staples or "securing rings" 16 and 17 are positioned about the circumference of the substantially cylindrically shaped graft 12.

Preferred staples are shown in FIGS. 3, 4, 9 and 10.

The staples 16 and 17 are collapsible from an initial diameter to a second smaller diameter. The initial diameter of the staples will be generally the same as the diameters 6 of the graft 12 and the same as or slightly larger than that of the lumen into which the graft 12 with staples 16 and 17 is to be placed. The second diameter will be the same or slightly smaller than inside diameter of the capsule 18. Also, the staples 16 and 17 will generally be made of a metal suitable for use in the body or biocompatible plastic. A stainless steel wire material is presently preferred because of its excellent spring characteristics. As best seen in FIG. 2, the staples 16 and 17 are positioned within the graft 12 and may even be stitched thereto. The staples 16 and 17 are sized to urge the graft 12 outwardly against the inside surface of the lumen into which the graft 12 is placed.

In one embodiment, the proximal staple 16 (FIG. 3) has a plurality of V-shaped support members 60. Each V-shaped support member 60 has an apex 62 with two "free ends" or legs, for example 60A, 60B, 60C and 60D. A free end 61A abuts and is adjoined to the free end 61B of another V-shaped support member 60 at an abutment point 63. The plurality of at least three V-shaped support members 60 are each connected one to another in a generally circular arrangement around the longitudinal axis 67 as shown. With the use of an elastically deformable or spring material, it can be seen that the staple of FIG. 3 can be compressed to make the "V" angle

65 smaller to in turn reduce the staple diameter to fit within the capsule 18.

5 A wall engaging member 70 is attached to each support member 60 generally along the length 66 of one of the legs 60A, 60B and preferably at or proximate each of at least three abutment points 63 of the proximal staple 16. The preferred wall engaging members 70 are barbs or elongated tine-like members with sharp points 71. The wall engaging members 70 are attached to the support 10 members at an angle 75 which may vary from about 15° to about 135° from the longitudinal or central axis 67 of the proximal staple 16. Preferably the wall engaging members 70 angulate away from the axis 67 in a downstream direction 100 (FIG. 6); and thus the angle 75 is 15 preferably less than 90° and desirably in the range from about 30° to about 60°.

It should be noted that the number or quantity of support members 60 is determined by the axial length 66 of the staple as well as by the cross sectional size of the lumen and in turn the capsule 18. FIG. 3 depicts a 20 plurality of six support members 60 which has been found to be suitable for use in the lumen of selected animals where the lumen is comparable in size to an adult aorta. That is, the lumen has an average or effective diameter of 25 about 12 to 18 millimeters.

It should also be noted that wall engaging members 70 are used to penetrate and hook into the interior surface of the lumen to hold the graft 12 in place. Although in some cases two wall engaging members 30 70 may be sufficient, it is preferred that at least three be provided. If the lumen is an artery or vein, some deformation is typically experienced so that actual penetration or hooking may be difficult with only two and hooking or penetration is facilitated by the use of three 35 or more. Of course it is most preferred that a wall engaging member be adapted to each support member to

facilitate engagement with the wall and also to assist in holding the upstream or proximal end of the graft 12 more securely against the wall of the lumen to minimize fluid (e.g., blood) leakage during the post-therapy healing process.

The proximal staple 16 may be unitarily formed, or may be constructed by interconnecting separate, V-shaped support members having vessel wall engaging members 70. That is, a stainless steel spring wire may be bent to form the apexes 62 and abutment points 63 and soldered or welded at a selected point to be unending as shown. Alternately, separate legs of support members 70 may be welded, glued or soldered together as appropriate to obtain desired strength.

A preferred proximal staple 104 (FIG. 9) is also comprised of a plurality of V-shaped support members 106. Each support member 106 has an apex 108 and two free ends or legs 110. A leg 110A abuts to and is adjoined to the leg 110B of another V-shaped support member 106A at an abutment point 112. The V-shaped support members 106 are connected one to another in a generally circular arrangement around the longitudinal axis 114 to form an unending fence-like arrangement similar to the arrangement of proximal staple 16 (FIG. 3).

In FIG. 9, wall engaging members 116 are adapted to the support members 106 at or near at least three abutment points 112 of the proximal staple 104. However, in the preferred proximal staple 104, an extension member 118 is also mounted to the staple 104 at abutment point 112. Each of these extension members 118 may have an optional and additional wall engaging member 120 attached thereto. The wall engaging members 116, 120 are all mounted to proximal staple 104 at an angle 122 comparable to angle 75 for staple 16 of FIG. 3. The preferred mounting angle of the vessel wall engaging members 116, 120 is from about 30° to about 60°. For ease in insertion

into wall of the lumen, wall engaging members 116, 120 are all preferably mounted generally at the same angle 122. That is, members 116 and 120 are in reality quite small and difficult to mount with precision. Thus the angles may vary as much as 10°. Further, the extension 118 is used to provide additional axial length to the staple 104 without affecting the size of the support member 106 and in turn the second or smaller diameter when collapsed inside capsule 18.

A distal staple 17 (FIG. 4) also preferably comprises a plurality of V-shaped support members 65. Each V-shaped support member is formed to have an apex 69, and two free ends or legs 71A and 71B. A free end 71A abuts and is adjoined to the free end 71B of another V-shaped support member 65 at an abutment point 73. The V-shaped support members 65 of the distal staple 17 are connected one to another in a generally circular arrangement similar to the staple shown in FIG. 3. At a plurality of the abutment points 73 wall engaging members 72 are attached generally at an angle 76 preferably perpendicular to the longitudinal axis 77 of the distal staple. The angle 76 between the wall engaging member 72 and the longitudinal axis 77 may vary between about 45° and about 115°. Preferably, the wall engaging members 72 of the distal staple are sufficiently short so as not to perforate the vessel wall.

A preferred distal staple 124 is depicted in FIG. 10. It has a plurality of V-shaped support members 126 formed with an apex 128 and two free legs 130A and 130B. A leg 130A abuts and is adjoined to the leg 130B of an adjacent V-shaped support member 126 at an abutment point 132. The V-shaped support members 126 of distal staple 124 connect one to another in a generally circular arrangement about axis 134 to form a fence-like arrangement similar to the staples shown in FIGS. 3 and 4.

Wall engaging members 136 are mounted at or near

-12-

at least three abutment points 132 of distal staple 124. Distal staple 126 has extension members 138 mounted at a plurality of abutment points 132 with a separate wall engaging member 140 mounted thereto, all similar to that shown for staple 106. As in distal staple 17, the wall engaging members 136, 140 are mounted to the staple 126 at an angle which may vary from about 45° to about 115°. Preferably the angle varies from about 75° to about 105°, and is most desirably generally perpendicular to axis 134. As in proximal staple 104, both the corresponding wall engaging members 136, 140 are mounted at the same angles to the staple 126.

The support members may also be U-shaped, as shown in FIG. 11 for all of the aforementioned staples 16, 17, 104 and 126. The arrangement would thus appear generally sinusoidal. In another alternative embodiment, the vessel wall engaging members 70, 72, 116, 120, 136 and 140 of FIGS. 3, 4, 9 and 10 may be barbed like fish hooks similar to barbed member 139 shown in FIG. 11.

Referring now to FIG. 6, portions of the system 11 (FIG. 1) for intraluminal engrafting are shown cross-sectionally within a lumen 90. The system 11 including the graft 12 and capsule 18 may be constructed in a variety of different sizes in order to accommodate and be compatible with a variety of differently sized (in cross-section) corporeal lumens. In FIGS. 6 and 7, the capsule 18 is shown to be smaller than the lumen 90 so that the various surfaces may be better illustrated. Typically, the cross-sectional size (i.e., area normal to axis 54) of the pertinent system components such as the capsule 18 and graft 12 are selected to be substantially the same as or slightly smaller than the lumen 90. It should be further recognized that the corporeal lumen 90 illustrated is substantially circular in cross-section. However, lumens such as blood vessels may vary widely in cross-section along their length but will elastically deform to receive

the capsule 18 and other components of the system 10. The lumens are also not straight in that they have many curves as they course throughout the body.

5 As shown in FIG. 5, the capsule 18 preferably has a rounded or tapered edge surface 92 between the side surface 94 and the front 20. The tapered surface 92 facilitates entry into and positioning within the lumen 90 by providing a contact surface to stretch the lumen especially in those places where the lumen 90 may be  
10 constricted or smaller in cross-section than the capsule 18 and the graft 12. A corporeal lumen such as a blood vessel or artery can stretch and deform. The tapered surface 92 can urge or force the deformation desired in order to facilitate placement as the capsule 18 is urged  
15 into and through the lumen 90 by exerting and emplacing force on the exterior end 96 of the tube 26.

The inside of the capsule 18 has a smooth bore cavity 98 (FIG. 6) formed therein sized to receive the graft 12. As can be seen, the catheter 27 may be  
20 centrally positioned within the cavity 98. Lead or guide wire 24 may be positioned within the lumen 90 in a manner known in the art and then threaded through the interior of the catheter 27. The tube 26 is affixed to the capsule 18 at its back 22 to extend rearwardly or downstream 100  
25 through an opening 102 made in the lumen for inserting the pertinent components of the system 10. The catheter 27 can slidably mate within the hollow tube 26.

The capsule 18 as shown in FIG. 5 has an aperture 19 formed in its front end 20 which is sized for  
30 passage of the graft 12 with staples 16 and 17. That is, the graft 12 with staples 16 and 17 are urged through aperture 19 for placement in the lumen 90 as hereinafter discussed. The capsule 18 is formed of any medically acceptable material. A variety of nylon and teflon  
35 materials are known to be acceptable along with selected metals. It is here preferred to use stainless steel as



the staples are easier to urge outwardly through the aperture 19. The connection means is structured to provide a smooth exterior surface as seen in FIG. 5.

5 As shown in FIG. 6, the graft 12 is positioned within the cavity 98 of the capsule 18. The graft 12 and staples 16 and 17 are preferably sized as hereinbefore discussed when in an undeformed condition to be slightly larger in cross-section than the cross-section of the lumen 90 and yet deformable to fit into the cavity 98. 10 An external or radial force is thereby exerted outwardly against the interior surface 104 of the cavity 98 to retain the graft 12 within the capsule 18. Further, the lumen engaging portion of the disclosed staples may frictionally engage the interior surface 104 of the 15 capsule 18 to further restrain and retain the graft 12 within the cavity during placement in the lumen.

As shown in FIG. 8, the capsule 18 preferably consists of two connecting tubular portions 88, 89 which mate together by connection means which are here shown to 20 be a coacting male threaded member 101B and female threaded member 101A. Such a construction is used to aid in placing the graft 12 within the capsule 18 so as to house it within the capsule 18. The proximal portion 89 of the capsule 18 can be disconnected from the distal 25 portion 88. The distal end 15 of graft 12 is then positioned within the distal portion 88 of the capsule 18. The proximal end 14 of the graft 12 is similarly positioned into the proximal portion 89 of the capsule which is then connected to the distal portion 88. The 30 catheter 27 is then extended into the capsule and the graft 12. The connection means is preferably selected to minimize the amount of relative rotation between the proximal and distal portions 88, 89 to minimize twisting of the graft 12.

35 Whatever the form of the capsule 18, it can be seen in FIG. 6 that an opening 102 is formed in the lumen

90 such as an artery, vessel or other similar corporeal lumen. A guide wire 24 may be then sequentially inserted therethrough and manipulated to a desired location. An appropriately sized capsule 18 with graft 12 are inserted through the opening 102 and into the lumen 90 over the guide wire 24. With the graft 12 in position as shown in FIG. 6, the capsule 18 is urged in an upstream direction by exerting a positioning force on the exterior 108 of tube 26 (FIG. 1). Then the catheter 27 may be inserted. Of course, the guide wires 24, catheter 27, and tube 26 are each sized to be of sufficient length 25 and 28 so that the capsule 18 and graft 12 may be positioned through the lumen 90 to a desired position which may be some distance from the entry point 102. It will also be recognized by those skilled in the art that appropriate radiological techniques such as fluoroscopy can be used to assist the user in positioning the capsule 18 and in turn the graft 12 at a precise desired position within the lumen 90. This position, in all likelihood, would be a diseased or damaged portion of the lumen 90 which is in need of repair. Upon reaching the desired position within the lumen 90, further forward or upstream movement within the lumen 90 is stopped. A clamp or other means may be placed about the catheter 27 outside the vessel to prevent movement of the catheter 27 relative to the tube 26. The tube 26 may also be secured or held by the user as desired.

The pusher button 31 and catheter 27 are then used to urge the graft forwardly or upstream through the aperture 19. The proximal end 14 of the graft 12 first leaves the capsule 18 as the pusher button engages portions of the distal end of the compressed proximal staple 16. For purposes of this illustration staples 16 and 17 (FIGS. 3 and 4) will be used. However, staples 104 and 126 could be substituted in their place as could any other equivalent staple. The pusher button 31 has a

-16-

diameter small enough to fit through the tube 26 and into the graft 12 and through aperture 19 of the capsule 18. The catheter 27 is maintained in a steady position while the tube 26 is moved downstream from the proximal staple 16. The balloon 30 may be inflated as shown in FIG. 6A to provide a holding force and resist relative movement as to the lumen 90. The pusher button 31 makes contact with pieces of the compressed proximal staple 16 urging the proximal staple through the aperture 19 of the capsule 18.

As the proximal staple 16 is pushed through the aperture 19 of the capsule 18 it springs open or expands, causing the wall engaging members 70 to contact with the wall of the lumen 90. After the proximal staple 16 has been completely removed from the capsule 18 and the wall engaging members 70 have made initial contact with the wall, the inflatable membrane 30 is moved to within the circumference of proximal staple 16 and graft 12. The inflatable membrane ("balloon") 30 is then inflated (see FIG. 7) by use of the inflation means 36 to urge the wall engaging members 70 into the wall surface of the lumen 90 to firmly lodge the proximal staple 16 and the graft 12 in place.

The capsule 18 is then moved downstream 100 even more to free the distal portion 15 of the graft 12 from the capsule 18 and exposing the distal staple 17 and wall engaging members 72 to the interior surface of the lumen 90. The balloon 30 may be deflated, moved to register with the staple 16 and inflated to ensure that the graft 12 remains securely positioned. After the distal portion 15 is free, the balloon 30 is deflated and moved to register with the distal staple 17. The balloon 30 is then reinflated to urge the wall engaging members 72 of the distal staple 17 into the wall thereby firmly securing the distal staple 17 and distal end 15 of the graft to the lumen 90. An angiogram may then be performed if desired

-17-

through the balloon catheter to determine the patency and security of the graft 12. Other balloon catheters may be used which do not have the main lumen to perform the angiogram. Thus, the guide wire is not then used and a  
5 separate angiogram catheter needed to perform a subsequent angiogram.

The balloon 30 is then deflated and the tube 26 with capsule 18 is withdrawn from within the lumen 90. After removing the tube 26 in its entirety, the catheter  
10 27 is thereafter removed and the opening 102 sealed. The back 22 of the capsule 18 may be formed to have a slightly rounded edge 89A to facilitate removal as shown in FIG. 8A.

After emplacement, it can be seen that the  
15 pressure of the lumen fluid, for example, blood, forces the graft 12 against the lumen interior surface 112, helping to hold the graft 12 in place. The bifolds 50 of the graft 12 permit deformation of the graft 12 to conform  
20 to the interior surface 112 of the lumen and provide for flexibility to bend and stretch with the natural lumen. Further, the bifolds 50 act somewhat as a mechanical labyrinth seal to reduce leakage between the interior  
25 surface of the lumen 112 and the exterior surface 84 of the graft 12. That is, the internal pressure of the fluid within the lumen 90 holds the graft 12 in place and assists the staples 16 and 17 in preventing leakage at both ends of the graft 12.

In operation, it should be noted that the system  
30 11 with the graft 12 is inserted into the lumen 90 using accepted surgical techniques. For example, an opening could be made through the leg to reach the main artery of a human being. Thereafter, the system 11 could be used as  
35 above described to emplace an artificial graft within the main artery as far interior the body as the myocardial or great artery area. This technique therefore avoids major surgery in which the chest or abdomen is penetrated for

repair of the aorta, vena cava or the like.

The components of system 11 are, of course, made of anatomically compatible substances. For example, the tube 26 and inflatable membrane 30 are made of a substantially chemically compatible plastic. The catheter 27 is made of a material such as Teflon to be flexible and sized in appropriate diameter and length to facilitate placement of the graft 12 in the desired location within the lumen 90.

Use of the system 11 with the graft 12 herein described may preclude the need for major surgery to repair a vessel, such as a blood vessel or artery in the great artery area. It can also be used to repair other vessels or ductiles within the body of a human being or animal. Use of the system may thus reduce the morbidity rates associated with major surgery. It also facilitates rapid repair of defective or damaged vessels at relatively low cost and risk. The system is mechanically simple and reliable and also useful for treating trauma victims in an emergency context.

It may be noted that the system 10 herein described, including the graft 12, are merely illustrative of the application of the principles of the invention. Reference herein to details of the illustrated embodiments is not intended to limit the scope of those claims which themselves recite those features regarded as essential to the invention.

Claims

What is claimed is:

5

1. A graft staple for use with an intraluminal graft comprising:

10

a plurality of three or more support members each having two legs joined to form an apex, with each of its legs joined to the legs of the adjacent support members to form a generally circular arrangement of support members about a central axis and operable between a first collapsed position for insertion into a lumen and a second expanded position upon placement at a selected location within said lumen; and

15

wall engaging members each attached to a selected support member, each wall engaging member extending outwardly from the central axis for engaging the wall of said lumen in said second expanded position.

20

25

2. The intraluminal graft staple of Claim 1 wherein each of the two legs of each support member have first ends and second ends and are joined at respective first ends to form said apex, and wherein said second ends of each said leg are joined to the second ends of the legs of adjacent support members to form a plurality of bottom apexes.

30

3. The graft staple of Claim 2 wherein one of said two legs has an extension section protruding beyond said apex.

35

4. The intraluminal graft staple of Claim 3 wherein said wall engaging members are attached to the said extension sections of said selected support members.

5. The intraluminal graft staple of Claim 4 wherein each of said legs are formed of a spring-like material and are essentially straight.

5 6. The intraluminal graft staple of Claim 5 wherein the legs of each of said support members extend away from said apex to together be generally "V" in shape.

10 7. The intraluminal graft staple of Claim 5 wherein the legs of each of said support members extend away from said apex to together be generally "U" in shape.

15 8. The intraluminal graft staple of Claim 5 wherein each of said wall engaging members are elongated tine-like members attached to its respective support members to extend away therefrom at an angle from the central axis of about 45° to about 115°.

20 9. The intraluminal graft staple of Claim 5 wherein said wall engaging members are attached to each of said support members at an angle from the central axis of about 15° to about 175°.

25 10. A hollow capsule for use in a system having means for placing intraluminal graft means into a corporeal lumen from exterior said corporeal lumen, said hollow capsule comprising:  
a proximal portion formed for passage through a corporeal lumen having a front end and a back end, said  
30 front end having an aperture sized for the passage of an intraluminal graft means therethrough;  
a distal portion formed for passage through said corporeal lumen and said back end of said distal portion  
35 being adapted for connection to said means for placing said intraluminal graft means into a

corporeal lumen from exterior said corporeal lumen;

5 connection means mechanically associated with said proximal and distal portions for interconnecting the bud ends of said proximal portion and the front end of said distal portion; and wherein said proximal and distal portions are together sized to removably receive said intraluminal graft means.

10 11. The hollow capsule of Claim 10 wherein said connection means is coating male-female threads, and wherein said proximal portion and said distal portion are each substantially the same in exterior cross-section at  
15 said connection means.

20 12. The hollow capsule of Claim 11 wherein said front end of said proximal portion tapers forward to down proximate its front end.

25 13. The hollow capsule of Claim 12 wherein said capsule is made of stainless steel.

30 14. A system for engrafting in a fluid conducting corporeal lumen comprising:  
a hollow graft of preselected cross-section and length having a proximal end and a distal end for placement within said corporeal lumen, said hollow graft being deformable to substantially conform to the interior surface of said corporeal lumen;  
35 a proximal staple positioned proximate the proximal end of said graft, said proximal staple being formed and positioned to urge said hollow graft against said interior surface and said proximal staple having lumen engaging members positioned and



having a lumen piercing member extending away therefrom for holding said proximal end of said hollow graft to and within said corporeal lumen; and

5 a distal staple positioned proximate the distal end of said hollow graft, said distal staple being formed and positioned to urge said hollow graft against said interior surface and having lumen engaging members positioned and adapted for  
10 holding said distal end of said hollow graft to and within said corporeal lumen; and  
placement means for placing and engrafting said hollow graft with said proximal and distal staples at a  
15 preselected position within and to said corporeal lumen.

15. The system of Claim 14 wherein said placement means includes:  
20 a capsule sized and shaped for positioning in and movement through said corporeal lumen and formed to have an interior sized and shaped to receive said hollow graft with said proximal and distal staples, said capsule having an aperture formed therein at one end thereof for passage of said  
25 hollow graft with said distal and proximal staples; and  
operation means associated with said capsule having portions which extend exterior said corporeal lumen for manipulation by a user, said hollow  
30 graft with said distal and proximal staples in said corporeal lumen and for urging said hollow graft and said distal and proximal staples through said aperture of said capsule.

35 16. The system of Claim 15 wherein said capsule has a back end with an aperture formed therein and wherein

said operation means includes a hollow tube connected to said capsule in communication with said aperture at the back end of the capsule, said hollow tube being sized to extend exterior the lumen for manipulation by the user.

5

17. The system of Claim 16 wherein said operation means includes a catheter sized in cross section to slide within said hollow tube and through said capsule and in length to extend from interior said capsule to exterior the lumen for manipulation by the user, said catheter having an inflatable membrane proximate its interior end and means in communication therewith for inflating and deflating said membrane.

10

15

18. The system of Claim 17 wherein said operation means includes pusher means securely mounted to the outside surface of the catheter proximate to and rearward of said inflatable membrane and sized to pass through the aperture at one end thereof and the aperture of the back end and for urging said hollow graft with said proximal and distal staples for urging said hollow graft with said proximal and distal staples out of said capsule through said aperture at one end thereof.

20

25

19. The system of Claim 18 wherein said pusher means is cylindrical in shape.

30

20. The system of Claim 18 wherein said capsule has a front end that is tapered.

35

21. The system of Claim 18 wherein said hollow graft is substantially cylindrical in shape and wherein said proximal and distal staples and said hollow graft are slidably positionable within said capsule, and wherein said pusher means is sized to contact said proximal staples for urging proximal staples and said graft from

said capsule downstream movement of said catheter relative to said first hollow tube.

5 22. A method for engrafting a tubular graft into a fluid conducting corporeal lumen comprising:

a tubular graft preselected in length with proximal and distal ends, said tubular graft being deformable to conform substantially to the interior surface of said corporeal lumen,

10 a proximal staple positioned near the proximal end of said tubular graft for urging and securing said tubular graft toward and against the interior surface of said corporeal lumen,

15 a capsule sized for positioning in said corporeal lumen, said hollow capsule to receive said tubular graft for positioning said tubular graft in said corporeal lumen and an aperture in the proximal end having a cross section selected for passage of the tubular graft with proximal staple, operations means associated with said capsule sized to extend exterior said corporeal lumen for manipulation by the user;

20 making an opening in a corporeal lumen sized for passing said capsule therethrough;

positioning said tubular graft with said proximal staple in said capsule;

30 inserting said capsule into said opening and urging said capsule upstream in said corporeal lumen to a desired location therewithin by manipulating said operation means;

35 operating the operation means to urge the tubular graft with said proximal staple through said aperture and into said corporeal lumen and urging said

-25-

proximal staple against the interior surface of said corporeal lumen to secure said tubular graft thereto;

5 removing said capsule from said vessel by manipulating the operation means; and  
closing said opening.

10 23. The method of Claim 16 further comprising the positioning of fluoroscopy means proximate the user to monitor the movement and positioning of said capsule and tubular graft.

15 24. A prosthesis for placement in a fluid conducting corporeal vessel, said prosthesis comprising: a hollow graft of pre-selected cross-section and length and having a proximal end for upstream placement within said vessel, said graft being deformable to conform substantially to the interior surface of said corporeal vessel; and  
20 an intraluminal graft staple having a plurality of support members joined one to another in a generally circular arrangement, a plurality of vessel wall engaging members each attached to a said support member to extend therefrom, said intraluminal graft staple being positioned proximate the  
25 proximal end of said hollow graft for urging said hollow graft against the said interior surface and said vessel wall engaging members into said corporeal vessel.

30 25. The intraluminal graft device of Claim 20 wherein said support members are substantially "V" in shape.

35 26. The intraluminal graft device of Claim 20 wherein said hollow graft is made of material having a

high tissue ingrowth rate.

5           27. The intraluminal graft device of Claim 21 wherein said hollow graft is made of a dacron and teflon mix material and is formed to be substantially cylindrical in shape prior to emplacement and to have a plurality of substantially evenly spaced circumferential bifolds along its length.

10           28. The intraluminal graft device of Claim 24 wherein said graft has a radio-opaque seam stitched therein in a longitudinal manner.

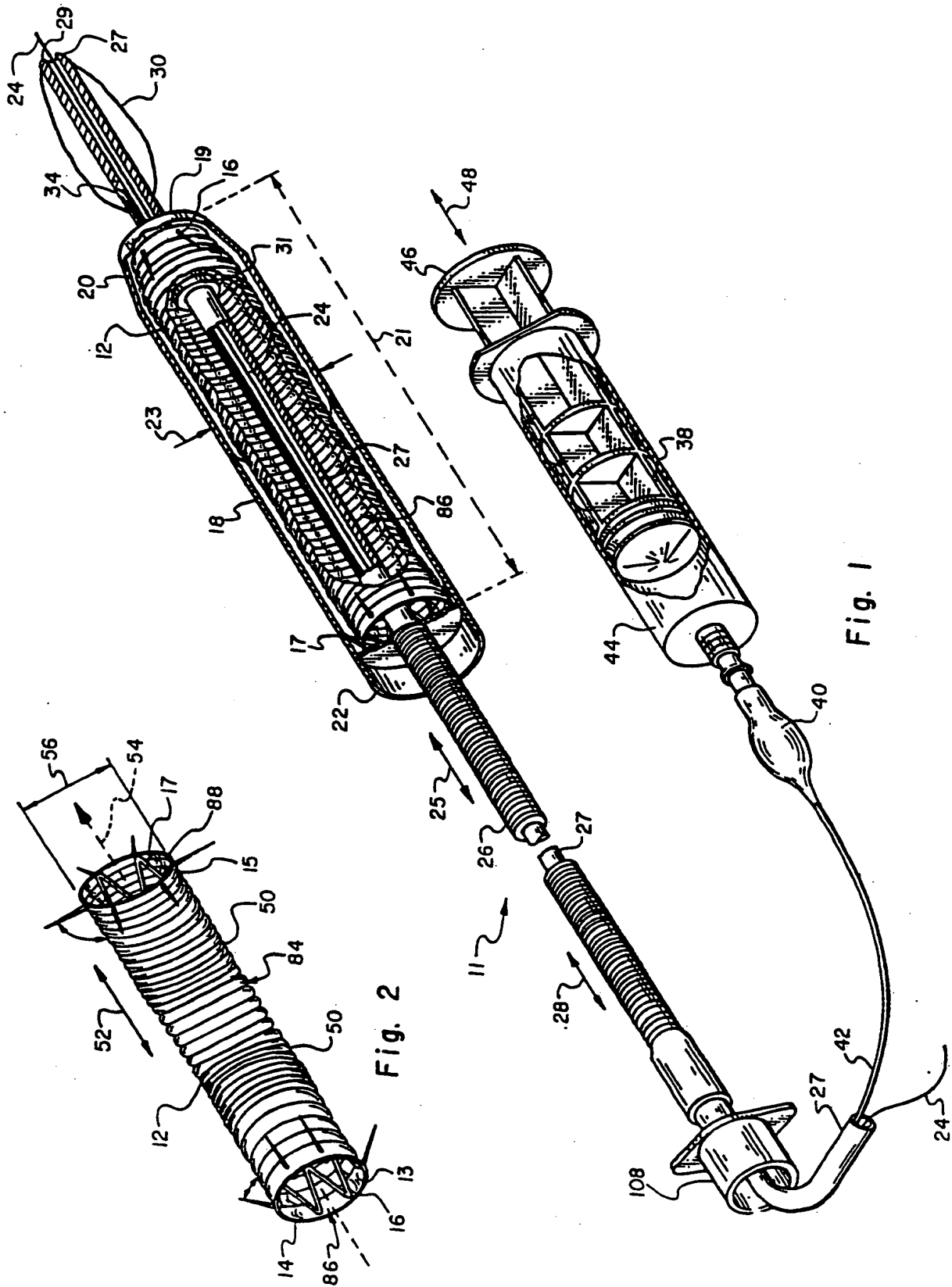

Fig. 1

Fig. 2

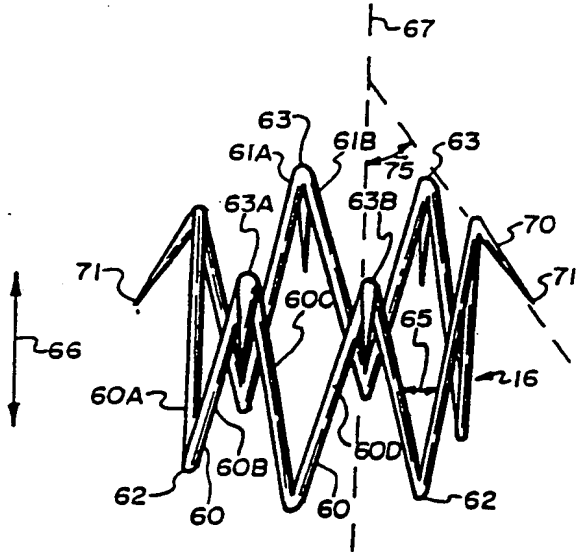

Fig. 3

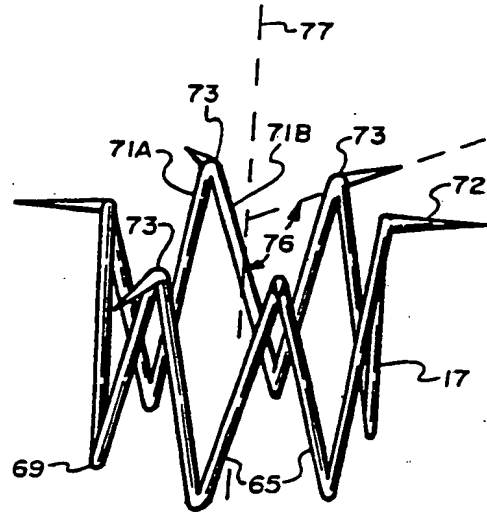

Fig. 4

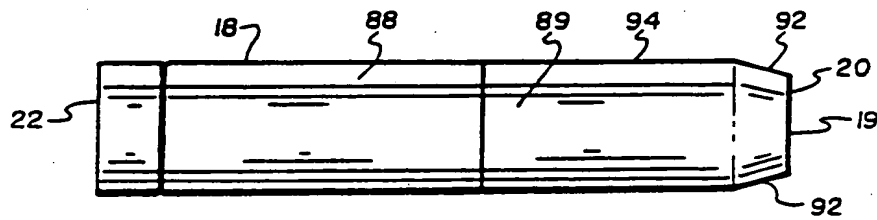

Fig. 5

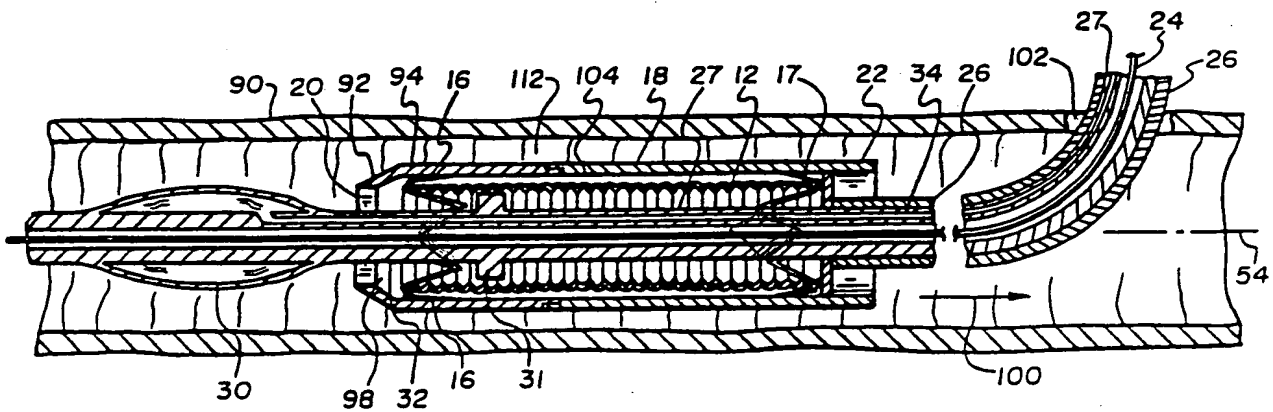

Fig. 6

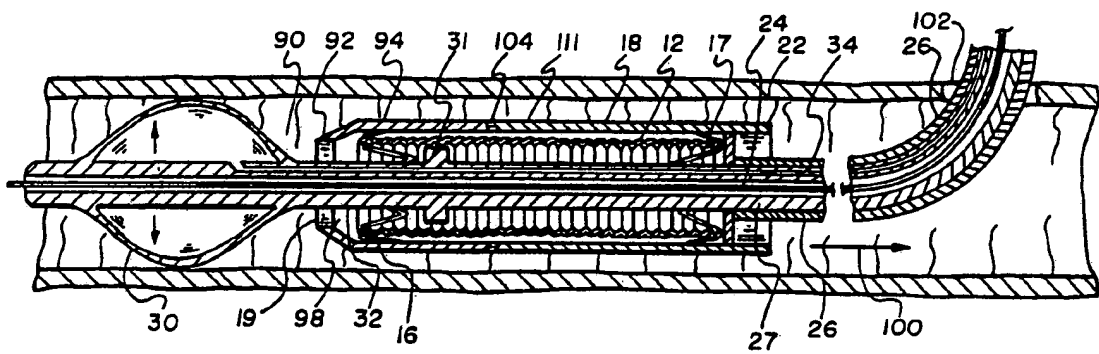

Fig. 6a



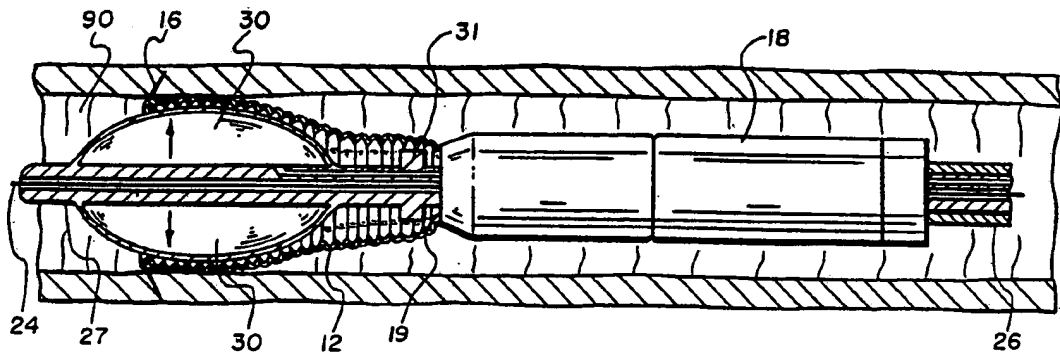

Fig. 7

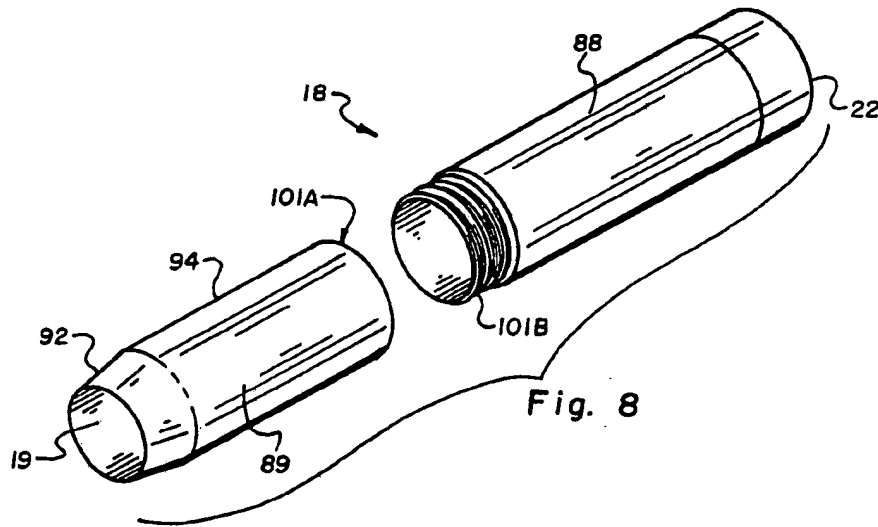

Fig. 8

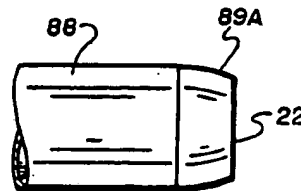

Fig. 8a

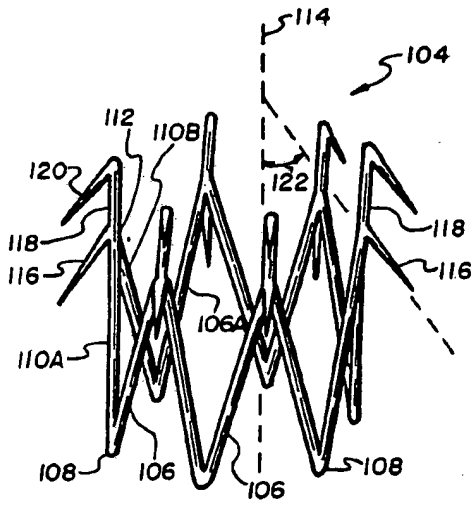

Fig. 9

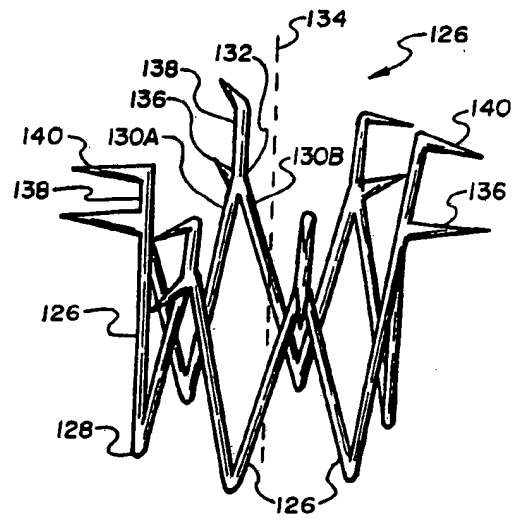

Fig. 10

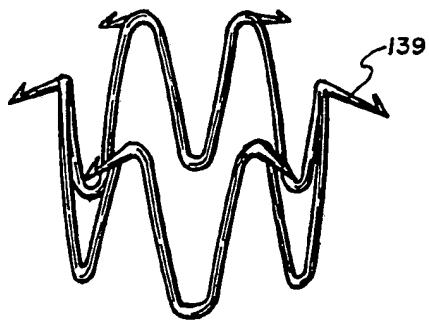
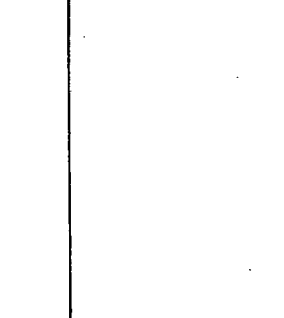

Fig. 11

# INTERNATIONAL SEARCH REPORT

International Application No. PCT/US89/00937

<b>I. CLASSIFICATION OF SUBJECT MATTER</b> (If several classification symbols apply, indicate all) <sup>6</sup>				
According to International Patent Classification (IPC) or to both National Classification and IPC				
IPC (4): A61F 2/04				
<b>II. FIELDS SEARCHED</b>				
Minimum Documentation Searched <sup>7</sup>				
Classification System	Classification Symbols			
U.S.	623/1,11,12 128,834			
Documentation Searched other than Minimum Documentation to the Extent that such Documents are Included in the Fields Searched <sup>8</sup>				
<b>III. DOCUMENTS CONSIDERED TO BE RELEVANT</b> <sup>9</sup>				
Category <sup>9</sup>	Citation of Document, <sup>11</sup> with indication, where appropriate, of the relevant passages <sup>12</sup>	Relevant to Claim No. <sup>13</sup>		
A, P	US, A, 4,787,899 (LAZARAUS) 29 November 1988 See claims 1-7.	1-28		
A, P	US, A, 4,776,337 (PALMAZ) 11 October 1988, See column 8, lines 9-32.	1-28		
A	US, A, 4,665,918 (GARZA, ET AL.) 19 May 1987 See column 5 lines 5-20.	1-28		
A	US, A, 4,617,932 (KORNBERG), 21 October 1986. See column 2, lines 55-69.	1-28		
A	US, A, 3,938,528 (BUCALO) 17 February 1976. See column 3, lines 5-40	1-28		
<table style="width: 100%; border: none;"> <tr> <td style="width: 50%; vertical-align: top; border: none;"> <p><sup>10</sup> Special categories of cited documents:</p> <p>"A" document defining the general state of the art which is not considered to be of particular relevance</p> <p>"E" earlier document but published on or after the international filing date</p> <p>"L" document which may throw doubts on priority claim(s) or which is cited to establish the publication date of another citation or other special reason (as specified)</p> <p>"O" document referring to an oral disclosure, use, exhibition or other means</p> <p>"P" document published prior to the international filing date but later than the priority date claimed</p> </td> <td style="width: 50%; vertical-align: top; border: none;"> <p>"T" later document published after the international filing date or priority date and not in conflict with the application but cited to understand the principle or theory underlying the invention</p> <p>"X" document of particular relevance; the claimed invention cannot be considered novel or cannot be considered to involve an inventive step</p> <p>"Y" document of particular relevance; the claimed invention cannot be considered to involve an inventive step when the document is combined with one or more other such documents, such combination being obvious to a person skilled in the art.</p> <p>"A" document member of the same patent family</p> </td> </tr> </table>			<p><sup>10</sup> Special categories of cited documents:</p> <p>"A" document defining the general state of the art which is not considered to be of particular relevance</p> <p>"E" earlier document but published on or after the international filing date</p> <p>"L" document which may throw doubts on priority claim(s) or which is cited to establish the publication date of another citation or other special reason (as specified)</p> <p>"O" document referring to an oral disclosure, use, exhibition or other means</p> <p>"P" document published prior to the international filing date but later than the priority date claimed</p>	<p>"T" later document published after the international filing date or priority date and not in conflict with the application but cited to understand the principle or theory underlying the invention</p> <p>"X" document of particular relevance; the claimed invention cannot be considered novel or cannot be considered to involve an inventive step</p> <p>"Y" document of particular relevance; the claimed invention cannot be considered to involve an inventive step when the document is combined with one or more other such documents, such combination being obvious to a person skilled in the art.</p> <p>"A" document member of the same patent family</p>
<p><sup>10</sup> Special categories of cited documents:</p> <p>"A" document defining the general state of the art which is not considered to be of particular relevance</p> <p>"E" earlier document but published on or after the international filing date</p> <p>"L" document which may throw doubts on priority claim(s) or which is cited to establish the publication date of another citation or other special reason (as specified)</p> <p>"O" document referring to an oral disclosure, use, exhibition or other means</p> <p>"P" document published prior to the international filing date but later than the priority date claimed</p>	<p>"T" later document published after the international filing date or priority date and not in conflict with the application but cited to understand the principle or theory underlying the invention</p> <p>"X" document of particular relevance; the claimed invention cannot be considered novel or cannot be considered to involve an inventive step</p> <p>"Y" document of particular relevance; the claimed invention cannot be considered to involve an inventive step when the document is combined with one or more other such documents, such combination being obvious to a person skilled in the art.</p> <p>"A" document member of the same patent family</p>			
<b>IV. CERTIFICATION</b>				
Date of the Actual Completion of the International Search	Date of Mailing of this International Search Report			
07 June 1989	23 JUN 1989			
International Searching Authority	Signature of Authorized Officer			
ISA/US	 David Isabella			

Form PCT/ISA/210 (second sheet) (Rev.11-87)